



IT Smontagomme automatici per autovetture e veicoli commerciali leggeri con pneumatici Low Profile e Run Flat.

EN Automatic tyre changers for cars and light commercial vehicles with Low Profile and Run Flat tyres.

FR Démonte pneus automatique pour voitures et véhicules commerciaux légers avec pneus Low Profile et Run Flat.

DE Automatische Reifenmontiermaschinen für Autos und leichte Nutzfahrzeuge mit Low-Profile und Run-Flat-Reifen.

ES Desmontadora de ruedas automática para coches y vehículos comerciales ligeros con neumáticos Low Profile y Run Flat.





IT Tecnologia LEVERLESS.
EN LEVERLESS system.
FR Système SANS DE LEVIER.
DE LEVERLESS Technologie.
ES Sistema SIN PALANCA.

IT Utensile automatico LEVERLESS ad azionamento pneumatico, con inserti di protezione in plastica **EN** LEVERLESS tool head with pneumatic operation, equipped with plastic protections **FR** Outil automatique SANS DE LEVIER à fonctionnement pneumatique, avec protections en plastique **DE** LEVERLESS Automatikwerkzeug mit Pneumatiktrieb und Schutzeinsätzen aus Kunststoff **ES** Útil automático SIN PALANCA de accionamiento neumático, con protecciones de plástico.

26"

IT Bloccaggio cerchi da 10" a 26".

EN Rim capacity from 10" to 26".

FR Blocage jantes de 10" à 26".

DE Felgenarretierung von 10" bis 26".

ES Bloqueo de llantas de 10" a 26".



IT Palo ribaltabile pneumaticamente con comando a pedale **EN** Pneumatic tilting column by pedal control **FR** Basculement du bras avec commande pneumatique à pédale **DE** Über Fußsteuerung pneumatisch neigbarer Ständer **ES** Columna neumática basculante con mando por pedal.

IT Braccio porta utensile e braccio orizzontale telescopico a bloccaggio pneumatico simultaneo **EN** Simultaneous pneumatic lock for tool head and horizontal telescopic arm **FR** Bras porte outil et bras horizontal télescopique à blocage pneumatique simultané **DE** Montagearm und horizontaler Teleskoparm mit gleichzeitiger pneumatischer Arretierung **ES** Brazo porta-útil y brazo horizontal telescópico con bloqueo neumático simultáneo.

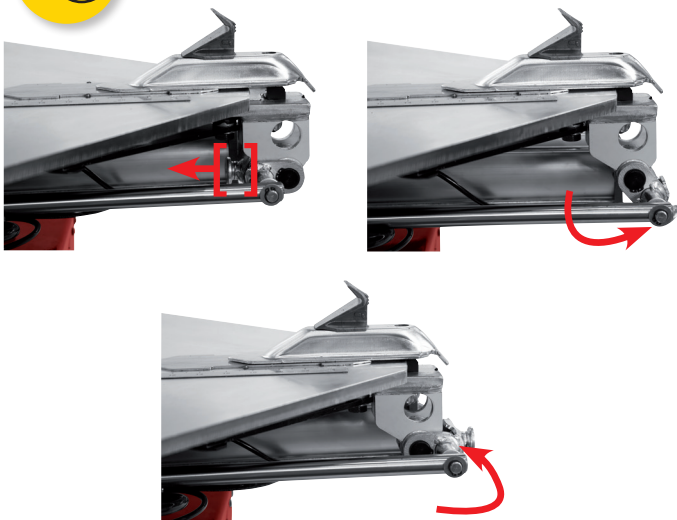

IT Regolazione manuale delle griffe per bloccaggio da 24" a 26" **EN** Manual regulation for wheel clamping lock from 24" to 26" **FR** Réglage manuel des mors pour le blocage de 24" à 26" **DE** Manuelle Regulierung der Spannbacken von 24" bis 26" **ES** Ajuste manual de las mordazas de sujeción de 24" a 26".



LIGRO GT

IT Versione GT dotata di dispositivo per il gonfiaggio dei pneumatici tubeless.

EN GT version equipped with special built-in device for tubeless tyre inflation.

FR Version GT avec gonfleur pour pneus tubeless.

DE Ausstattung der Version GT mit einer Vorrichtung zur Befüllung von Tubeless-Reifen.

ES Versión GT equipada con dispositivo de inflado de neumáticos tubeless.

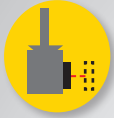

IT Appoggio stallonatore regolabile **EN** Adjustable bead breaker support **FR** Appui décolleur réglable **DE** Regulierbare Abdrückerhalterung **ES** Apoyo del destalonador ajustable.

IT Cilindro stallonatore in acciaio inox a doppio effetto **EN** Double acting bead breaker cylinder in stainless steel **FR** Vérin décolleur en acier inox à double effet **DE** Doppelt wirkender Abdrückzylinder aus Edelstahl **ES** Cilindro destalonador de acero inoxidable de doble efecto.



IT Velocità di rotazione variabile (motoinverter) con comando a pedale **EN** Variable rotation speed (motoinverter) by pedal control **FR** Vitesse de rotation variable (motoinverter) avec commande a pédale **DE** Variable Rotationsgeschwindigkeit (Geschwindigkeitsinverter), Fußsteuerung **ES** Velocidad de rotación variable (motoinverter) con mando a pedal.

Dotazione Standard • Standard Accessories

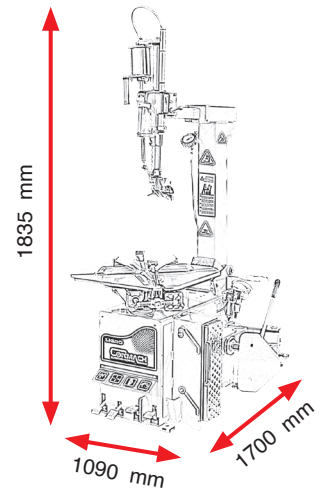
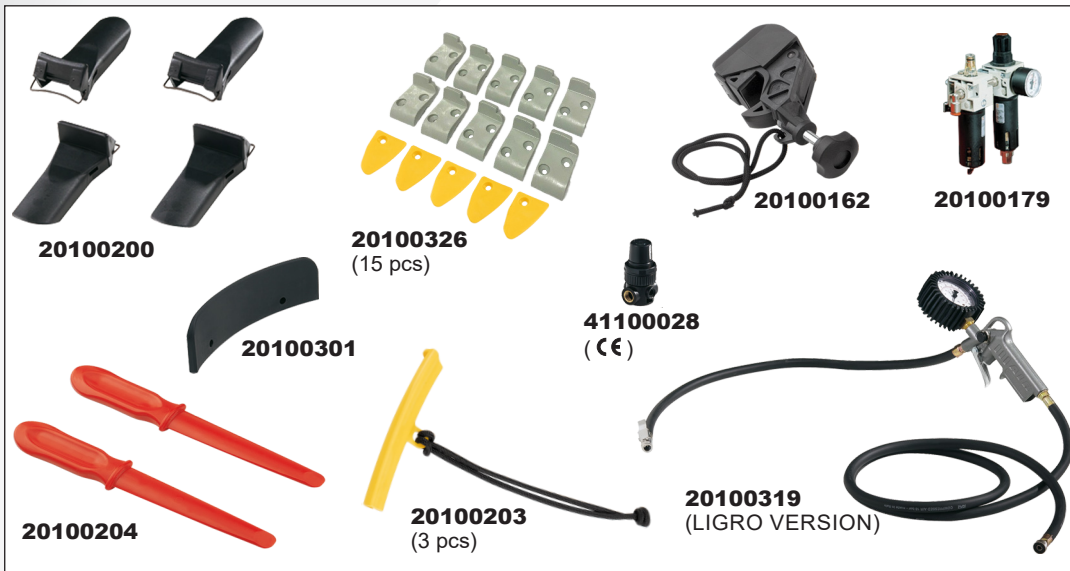

Accessori Opzionali • Optional Accessories

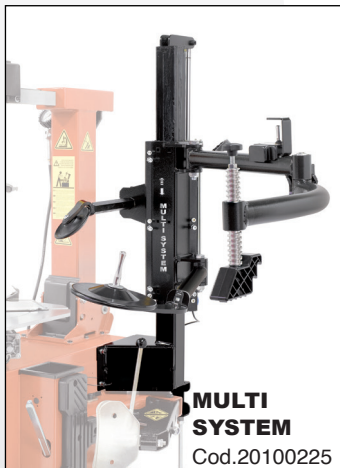

Dati tecnici • Technical data • Données techniques • Technisches Daten • Datos técnicos

• Diametro massimo ruota • Max wheel diameter	• Larghezza massima ruota • Max wheel width	• Bloccaggio esterno • Outside locking capacity	• Bloccaggio interno • Inside locking capacity	• Pressione di esercizio • Working pressure	• Alimentazione • Power supply	• Forza stallonatore • Bead breaker power	• Apertura max stallonatore • Bead breaker max opening	• Velocità di rotazione • Rotation speed	• Peso netto • Net weight
• Diamètre maximal de la roue • Max. Radaussendurchmesser • Diámetro máx de la rueda	• Largeur maximal de la roue • Max. Reifenbreite • Ancho máx de la rueda	• Blocage extérieur • Aussenseitige Aufspannen • Para ruedas de exterior	• Blocage intérieur • Innerseitige Aufspannen • Para ruedas de interior	• Pression de travail • Betriebsdruck • Presión de trabajo	• Alimentation • Stromversorgung • Alimentación	• Force décolleur • Abdrückerkraft • Fuerza destalonador	• Ouverture maxi décolleur • Max Öffnung Abdrückschaufel • Apertura máx destalonador	• Vitesse de rotation • Dreh-Geschwindigkeit • Velocidad de rotación	• Poids net • Nettogewicht • Peso neto
1100 mm (43")	360 mm (14")	10" - 24"	13" - 26"	8 - 10 bar	230V 50-60 Hz 1ph	2800 Kg	380 mm	6 - 12 rpm	256 Kg 269 Kg - GT